



*At the Heart of Community*

# Decks

## Materials

\*No. 2 pressure treated pine is the minimum grade beam size permitted.



## Rules & Restrictions

\*All work shall include all items required by the 2012 International Residential Code, including, but not limited to, the items listed on the attached checklist.

\*Decks with roof structures and screen rooms attached to the house must refer to the addition handout and requirements.

\*Piers shall be a minimum of 8" diameter and 42" below grade.

\*Decks shall be designed to a minimum live load of 40 lbs. per sq. ft, balconies at 60 lbs.

\*Piers are required for the support of all stairs.

\*Remove all vegetation below your deck. Install a landscape fabric or similar material and cover with a minimum of 2" of gravel.

\*Posts shall be anchored to the concrete piers with approved galvanized metal anchors.

\*Pre-cast concrete pads on grade for deck support are not permitted.

\*Any deck attached to a cantilever greater than 2 ft. requires additional piers and beams.

## What to Submit

\*Completed application.

\*2 copies of a Certified Plat of Survey with the proposed location of the deck and stairs drawn to scale with dimensions. Indicate side and rear setbacks.

\*2 copies of plan details drawn to scale with dimensions, elevations, and details of the deck construction. Include elevation showing finished grade.

## Inspections

\*Inspections are scheduled for A.M. or P.M. Monday through Friday with 48 hours advance notice. Call before 1:00 P.M. two business days before you want your inspection. Same day re-inspections are not available.

\*Pre-pour inspection – after pier holes or trench foundation are excavated.

\*Framing inspection – prior to installation of the decking material.

\*Final inspection

## Locations

\* Decks shall maintain a minimum 7' side yard setback for subdivisions before 1991 or as the subdivision was platted (whichever is greater). In most cases a 10' side yard is required for subdivisions after 1991.

\*Decks shall not be located within 23' of the rear lot line.

\*Decks shall not be located in any easement.

## Costs

\$44.00 Plan Review Fee

\$75.00 Permit Fee

\$75.00 Electrical Fee (min) (if necessary)

\$105.00 Building Deposit -refunded in accordance with Municipal Code Title 8, Chapters 2-6, Sections A-E. Allow 4-6 weeks for refund after final inspection has taken place.

\*If final inspection is not scheduled and approved prior to expiration date on permit, the building deposit will be forfeited to the Village.

## Note:

\*If an inspector needs to return more than once for the same phase of any required inspection, a \$85.00 re-inspection fee will be required to be paid before the re-inspection takes place.

**I have read and reviewed these requirements.**

\_\_\_\_\_  
Signature of Applicant

\_\_\_\_\_  
Date

\_\_\_\_\_  
Address



*At the Heart of Community*

This checklist for deck construction is **only a summary** of the code requirements based on the 2012 International Residential Code.

### The plans shall include

- The deck ledger shall be attached to the house with minimum ½ inch through or Lag bolts, two at each end and at a maximum 24-inches o.c. staggered. Install flashing or caulk to weatherproof the ledger.
- Beams must be fastened to the posts with a minimum of a 3/8-inch bolt or an approved galvanized post anchor.
- Joist hangers shall be installed at all locations where joists exceed 24" in length where the joists butt into headers, beams or ledgers. Install with approved nails only.
- All posts shall be bolted to the deck framing with minimum 1/2" threaded through bolts.
- Decks 48" or greater above grade require diagonal bracing at least 30" in length at all posts.
- Guardrails are required on all surfaces 30" or more above the adjacent surface below the deck. This includes stairs and seats on decks.
- Guardrails shall be a minimum of 36" in height except that stairs required to have guardrails may have guardrails a minimum of 34" in height.
- Guardrails may be closed. Open guardrails shall have vertical members that will not allow the passage of an object 4" in diameter. Guardrails designed with a ladder affect are not permitted.
- Decks may be cantilevered a maximum of 24-inches. Cantilevers exceeding 24-inches shall require a structural design signed and sealed by a design professional.
- Framing and decking material is to be pressure treated or of decay resistant material.
- Bridging is required when joist spans are greater than 10' between support beams.

### The plans shall include (cont.)

- Notching, cutting, drilling or altering joists, beams and supports is strictly controlled by the Code. If you have any questions, please call the Plans Examiner (540-1696) for further information.
- Headers and adjacent framing shall be doubled and properly nailed together.
- Please include your deck's height above grade on all plans.
- Include a plan view of all front, rear and/or side elevations. Include a detail indicating the method of attaching the deck to the house. See sample plan attached.
- The plans shall indicate all electrical lines, meter locations, pedestals, windows/window wells, exhaust vents or items located within the construction area.

### General Stair Requirements

- Handrails shall have a minimum height of 34" and a maximum height of 38".
- Handrails are required on all stairs with three or more risers.
- Stairs are required to be a minimum of 36" wide. Stairs in excess of 36" in width shall have an additional stringer for each 36" in width or part thereof.
- Stair treads shall be a minimum of 10" deep.
- Stair risers shall have a maximum height of 7 3/4".
- Indicate the location and depth of the piers
- Stair tread and riser measurements must be consistent throughout the run of the stair.
- Stair locations shall be indicated on the plans in their exact location.



## Community Development Department

505 Telser Road  
Lake Zurich, IL 60047  
P: (847) 540-1696 F: (847) 726-2182  
www.LakeZurich.org  
Permits@LakeZurich.org

# Permit Application

Date of Application \_\_\_\_\_

### Project Information

Property Address: \_\_\_\_\_

Type of Project: \_\_\_\_\_ Business Name: \_\_\_\_\_

Owner's Name/Address: \_\_\_\_\_ (If different from above) \_\_\_\_\_  
(For commercial/industrial applications only)

Owner's Phone: \_\_\_\_\_

Value of proposed construction/improvements: \$ \_\_\_\_\_ Owner's Email: \_\_\_\_\_

### Description of Work

\_\_\_\_\_  
\_\_\_\_\_  
\_\_\_\_\_

### Contractor Information

Contractors are required to be registered with the Village of Lake Zurich. Please refer to the Contractor Registration Application.

General Contractor: \_\_\_\_\_ Phone: \_\_\_\_\_

Address: \_\_\_\_\_ E-mail: \_\_\_\_\_

Other Contractor: \_\_\_\_\_ Type: \_\_\_\_\_ Phone: \_\_\_\_\_

Address: \_\_\_\_\_ E-mail: \_\_\_\_\_

Other Contractor: \_\_\_\_\_ Type: \_\_\_\_\_ Phone: \_\_\_\_\_

Address: \_\_\_\_\_ E-mail: \_\_\_\_\_

I hereby certify that I am the owner of record of the named property, or that the proposed work is authorized by the owner of record and that I have been authorized by the owner to make this application as his/her authorized agent and I agree to conform to all applicable laws of this jurisdiction. In addition, if a permit for work described in this application is issued, I certify that the code official's authorized representative shall have the authority to enter areas covered by such permit at any reasonable hour to enforce the provisions of the code(s) applicable to such permit.

Printed Applicant Name: \_\_\_\_\_ Phone: \_\_\_\_\_

Applicant Signature: \_\_\_\_\_ Owner or Contractor

Property Owner Signature: \_\_\_\_\_ (Please Select One)

Application must be signed by the property owner. A signed letter of authorization/contract from the property owner must be submitted with the application in lieu of signature on application.

Director of Building and Zoning Signature: \_\_\_\_\_ Date: \_\_\_\_\_

# Residential Deck Drawings

## General Notes Checklist

- 1) All lumber shall be pressure-treated for exterior use. All metal fasteners and hangers shall be G1 85 galvanized, stainless steel, or otherwise compatible with the wood treatment. All bolts shall be 1/2" diameter, minimum.
- 2) All beams, joists, posts, and decking shall be number 2 southern pine, or better.
- 3) All beam or top rail splices shall occur at a post or otherwise on adequate bearing.
- 4) All footings shall be cast in place concrete with a minimum 2500 psi compressive strength.
- 5) Guards are required at all areas where the deck/porch floor is greater than 30 inches above grade at any point.
- 6) Required guards shall be a minimum of 36 inches tall and be constructed such that a 4 inch diameter object will not pass through.
- 7) Required guards and handrails at stairs shall range from 30 inches to 38 inches vertically above the stair nosings.
- 8) Handrail ends at the top and bottom, shall terminate into a post or be returned to a wall.
- 9) Maximum stair riser height shall be 7-3/4". The minimum tread depth shall be 10". The greatest riser height or tread depth cannot exceed the smallest riser height or tread depth by more than 3/8".
- 10) Guards shall be designed for a 200 pound concentrated load placed along the top rail in any direction, at any point.
- 11) The deck/porch floor shall be within 7 1/2 inches of the top of the door threshold.
- 12) Design loads:
  - Floor live load 40 pounds per square foot (minimum); dead load 10 pounds per square foot (minimum)
  - Windspeed – 90 mph.
  - Soil bearing pressure – 3000 pounds per square foot
- 13) This deck/porch is **not designed for hot tub or spa loading.**
- 14) Post size is based on the height of the deck floor above finished grade at the highest point:
  - 0' to 8' high: 4 x 4, 4 x 6, 6 x 6
  - 8' to 10' high: 4 x 6, 6 x 6
  - 10' and higher: 6 x 6 (required for multilevel decks also)
- 15) Bridging is recommended at the mid span of all joists.
- 16) The actual field construction shall match the approved plans. All field changes and/or deviations require Building Department approval.
- 17) Type of Decking \_\_\_\_\_

## Framing Table for Single Span Decks

Live load = 40 PSF Dead load = 10 PSF

[1] Choose one deck joist size with the associated span, [2] Choose one deck beam size. Entire row applies.

	Joist Length	JOIST SIZE	BEAM TYPE AND PIER SPACING												
			4	5	6	7	8	9	10	11	12	13	14		
		16" O.C.													
FLOOR JOIST LENGTH	6 - Feet	1-2 X 6	2-2 X 6	2-2 X 6	2-2 X 6	2-2 X 6	2-2 X 6	2-2 X 6	2-2 X 6	2-2 X 8	2-2 X 8	2-2 X 8	2-2 X 10		
	7 - Feet	1-2 X 6	2-2 X 6	2-2 X 6	2-2 X 6	2-2 X 6	2-2 X 6	2-2 X 6	2-2 X 8	2-2 X 8	2-2 X 8	2-2 X 10	2-2 X 10		
	8 - Feet	1-2 X 6	2-2 X 6	2-2 X 6	2-2 X 6	2-2 X 6	2-2 X 6	2-2 X 6	2-2 X 8	2-2 X 8	2-2 X 8	2-2 X 10	2-2 X 10	2-2 X 12	2-2 X 12
	9 - Feet	1-2 X 6	2-2 X 6	2-2 X 6	2-2 X 6	2-2 X 6	2-2 X 6	2-2 X 6	2-2 X 8	2-2 X 8	2-2 X 10	2-2 X 10	2-2 X 12	2-2 X 12	
	10 - Feet	1-2 X 8	2-2 X 8	2-2 X 8	2-2 X 8	2-2 X 8	2-2 X 8	2-2 X 8	2-2 X 8	2-2 X 10	2-2 X 10	2-2 X 12	2-2 X 12	3-2 X 10	
	11 - Feet	1-2 X 8	2-2 X 8	2-2 X 8	2-2 X 8	2-2 X 8	2-2 X 8	2-2 X 8	2-2 X 10	2-2 X 10	2-2 X 10	2-2 X 12	2-2 X 12	3-2 X 12	
	12 - Feet	1-2 X 8	2-2 X 8	2-2 X 8	2-2 X 8	2-2 X 8	2-2 X 8	2-2 X 8	2-2 X 10	2-2 X 10	2-2 X 10	2-2 X 12	3-2 X 10	3-2 X 12	
	13 - Feet	1-2 X 10	2-2 X 10	2-2 X 10	2-2 X 10	2-2 X 10	2-2 X 10	2-2 X 10	2-2 X 10	2-2 X 10	2-2 X 12	2-2 X 12	3-2 X 12	3-2 X 12	
	14 - Feet	1-2 X 10	2-2 X 10	2-2 X 10	2-2 X 10	2-2 X 10	2-2 X 10	2-2 X 10	2-2 X 10	2-2 X 10	2-2 X 12	3-2 X 10	3-2 X 12		
	15 - Feet	1-2 X 12	2-2 X 10	2-2 X 10	2-2 X 10	2-2 X 10	2-2 X 10	2-2 X 10	2-2 X 10	2-2 X 10	2-2 X 12	3-2 X 10	3-2 X 12		
16 - Feet	1-2 X 12	2-2 X 12	2-2 X 12	2-2 X 12	2-2 X 12	2-2 X 12	2-2 X 12	2-2 X 12	2-2 X 12	3-2 X 12	3-2 X 12	3-2 X 12			
17 - Feet	1-2 X 12	2-2 X 12	2-2 X 12	2-2 X 12	2-2 X 12	2-2 X 12	2-2 X 12	2-2 X 12	2-2 X 12	3-2 X 12	3-2 X 12	3-2 X 12			

1: Choose one joist size \_\_\_\_\_ 2: Choose one beam size \_\_\_\_\_

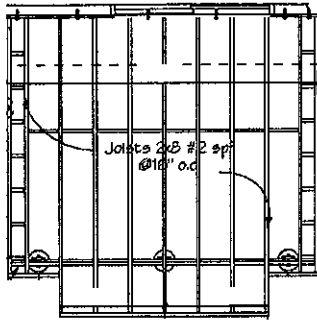

Single Span Deck

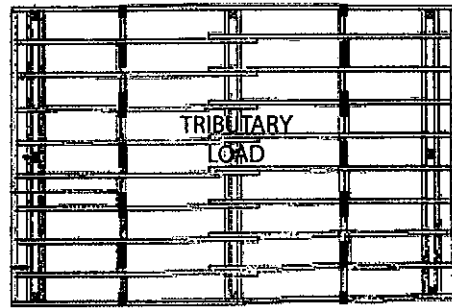

Multi-Span Deck

### Framing Table for Multi-Span Decks

Live load = 40 PSF Dead load = 10 PSF

Tributary Load	Post Spacing/ Beam Length	Minimum Beam Size Center Span
3 Feet	6 Feet	1 - 2 X 6
3 Feet	7 Feet	2 - 2 X 6 1 - 2 X 8
3 Feet	8 Feet	2 - 2 X 6 1 - 2 X 10
3 Feet	9 Feet	2 - 2 X 6
3 Feet	10 Feet	2 - 2 X 8
4 Feet	6 Feet	2 - 2 X 6 1 - 2 X 8
4 Feet	7 Feet	2 - 2 X 6 1 - 2 X 8
4 Feet	8 Feet	2 - 2 X 8 1 - 2 X 10
4 Feet	9 Feet	2 - 2 X 8
4 Feet	10 Feet	2 - 2 X 8
5 Feet	6 Feet	2 - 2 X 8 1 - 2 X 10
5 Feet	7 Feet	2 - 2 X 8 1 - 2 X 10
5 Feet	8 Feet	2 - 2 X 8
5 Feet	9 Feet	2 - 2 X 8
5 Feet	10 Feet	2 - 2 X 10
6 Feet	6 Feet	2 - 2 X 8 1 - 2 X 10
6 Feet	7 Feet	2 - 2 X 8 1 - 2 X 10

Tributary Load	Post Spacing/ Beam Length	Minimum Beam Size Center Span
6 Feet	8 Feet	2 - 2 X 8 1 - 2 X 12
6 Feet	9 Feet	1 - 2 X 10
6 Feet	10 Feet	2 - 2 X 10
7 Feet	6 Feet	2 - 2 X 8 1 - 2 X 10
7 Feet	7 Feet	2 - 2 X 8 1 - 2 X 12
7 Feet	8 Feet	2 - 2 X 10
7 Feet	9 Feet	2 - 2 X 10
7 Feet	10 Feet	2 - 2 X 12
8 Feet	6 Feet	2 - 2 X 8 1 - 2 X 10
8 Feet	7 Feet	2 - 2 X 8 1 - 2 X 12
8 Feet	8 Feet	2 - 2 X 10
8 Feet	9 Feet	2 - 2 X 12
8 Feet	10 Feet	2 - 2 X 12
9 Feet	6 Feet	2 - 2 X 8
9 Feet	7 Feet	2 - 2 X 10
9 Feet	8 Feet	2 - 2 X 10
9 Feet	9 Feet	2 - 2 X 12
9 Feet	10 Feet	3 - 2 X 10
10 Feet	6 Feet	2 - 2 X 8

Tributary Load	Post Spacing/ Beam Length	Minimum Beam Size Center Span
10 Feet	7 Feet	2 - 2 X 10
10 Feet	8 Feet	2 - 2 X 12
10 Feet	9 Feet	2 - 2 X 12
10 Feet	10 Feet	3 - 2 X 12
11 Feet	6 Feet	2 - 2 X 8
11 Feet	7 Feet	2 - 2 X 10
11 Feet	8 Feet	2 - 2 X 12
11 Feet	9 Feet	3 - 2 X 10
11 Feet	10 Feet	3 - 2 X 12
12 Feet	6 Feet	2 - 2 X 8
12 Feet	7 Feet	2 - 2 X 10
12 Feet	8 Feet	2 - 2 X 12
12 Feet	9 Feet	3 - 2 X 12
13 Feet	6 Feet	2 - 2 X 10
13 Feet	7 Feet	2 - 2 X 12
13 Feet	8 Feet	3 - 2 X 10
13 Feet	9 Feet	3 - 2 X 12
14 Feet	6 Feet	2 - 2 X 10
14 Feet	7 Feet	2 - 2 X 12
14 Feet	8 Feet	3 - 2 X 10
14 Feet	9 Feet	3 - 2 X 12

### Beam to Post Connection Options

[3] Choose one beam to post connection option. [4] Choose one post size based on the height of the deck.

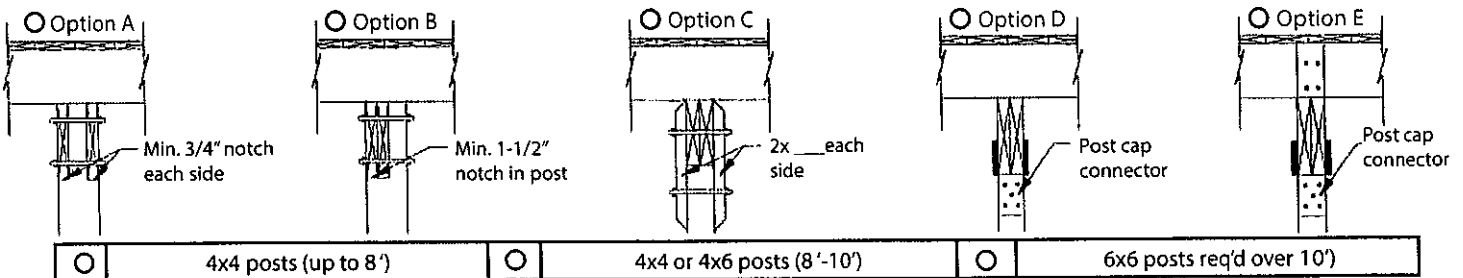

# Foundation & Framing Plan

Choose one span configuration:  
 Single-Span  
 Multi-Span

*The actual field construction shall match the approved plans. All field changes and/or deviations require Building Dept. approval. (And as built plans)*

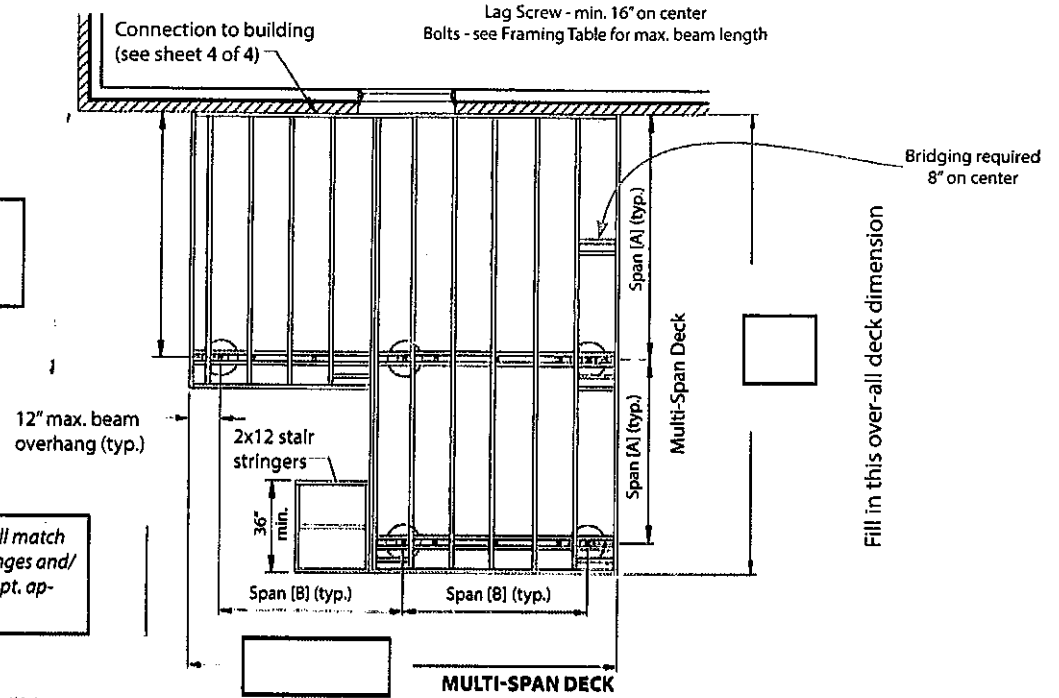

# Deck Finished Floor Plan

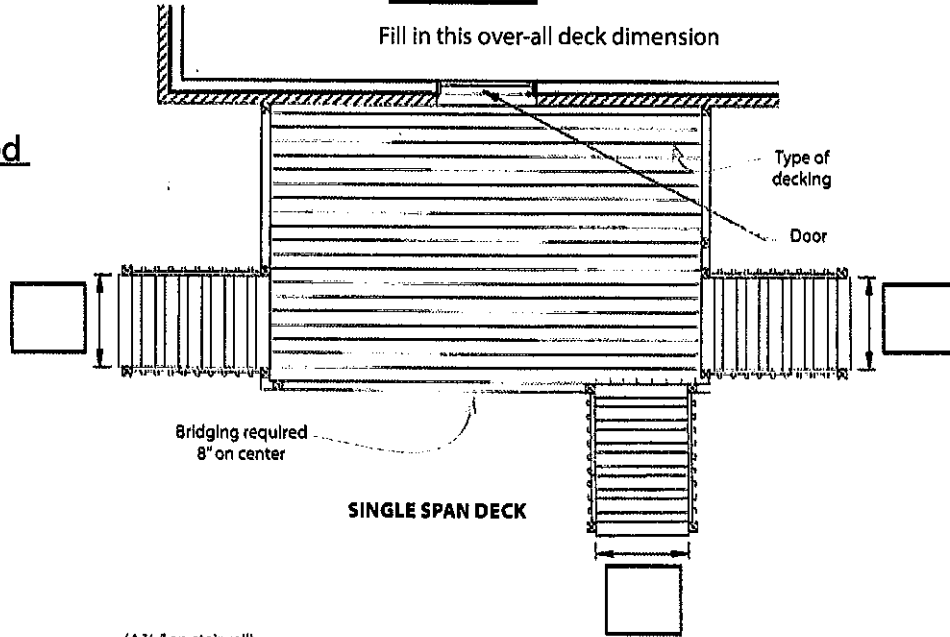

# Front Elevation View

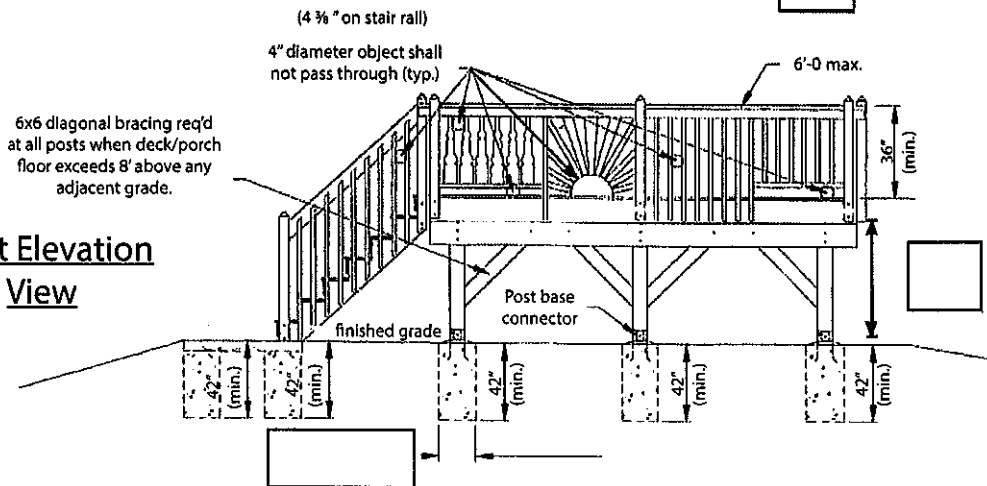

## Left Side Elevation View

The actual field construction shall match the approved plans. All field changes and/or deviations require Building Dept. approval.

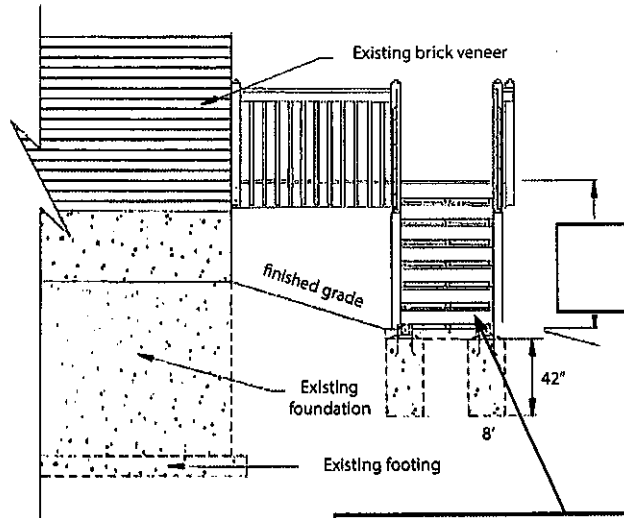

Fill in the highest point above grade in inches

Open risers are permitted provided that the opening between treads does not permit the passage of a 4-inch-diameter sphere.

Exception: The opening between adjacent treads is not limited on stairs with a total rise of 30 inches or less.

## Stair Section View

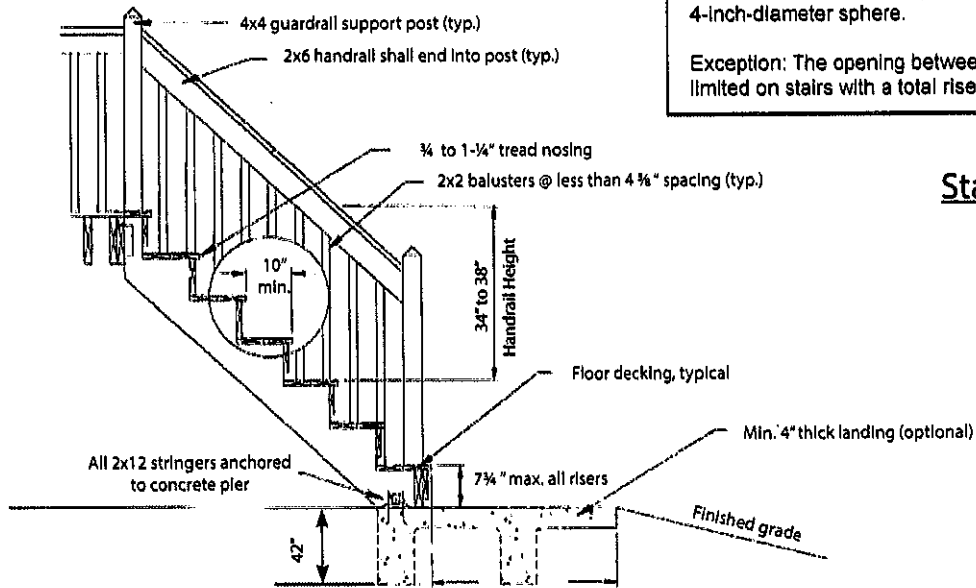

## Option 2

## Handrail Sections

Choose a handrail grip style:

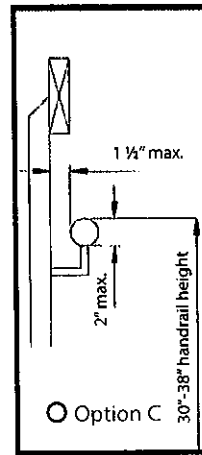
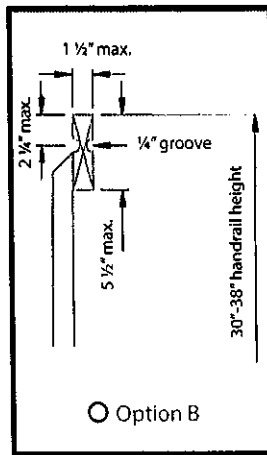
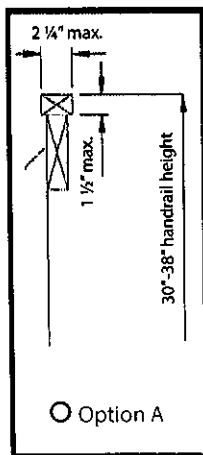

## Post & Beam Detail

The actual field construction shall match the approved plans. All field changes and/or deviations require Building Dept. approval.

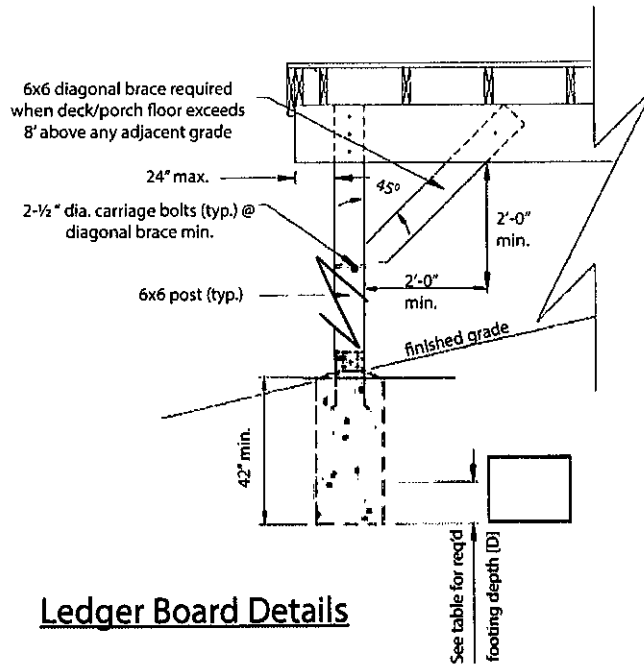

## Ledger Board Details

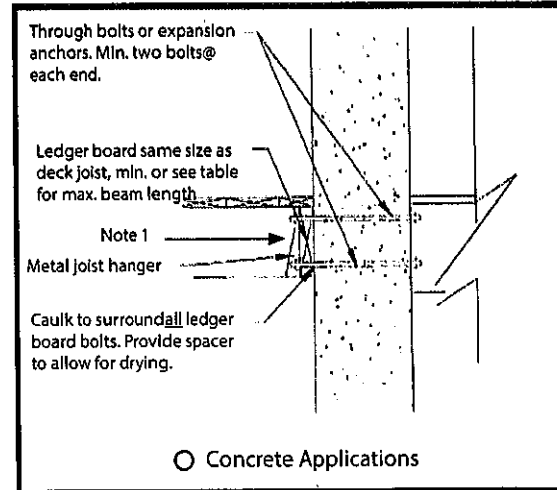
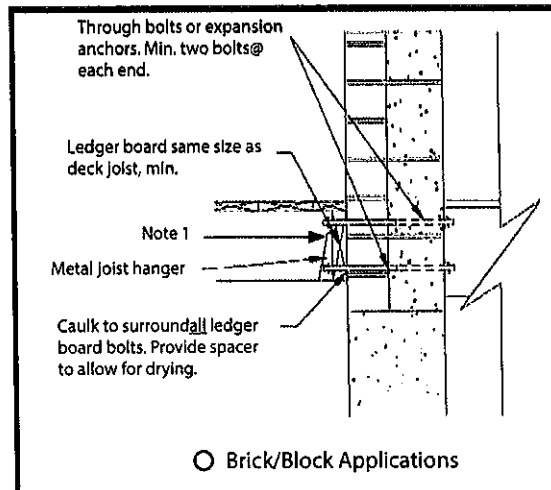
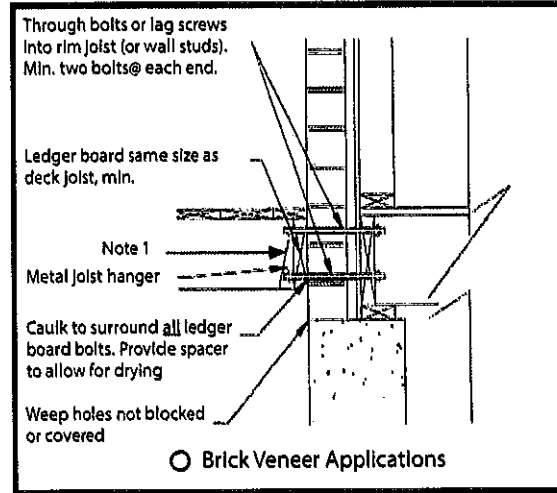
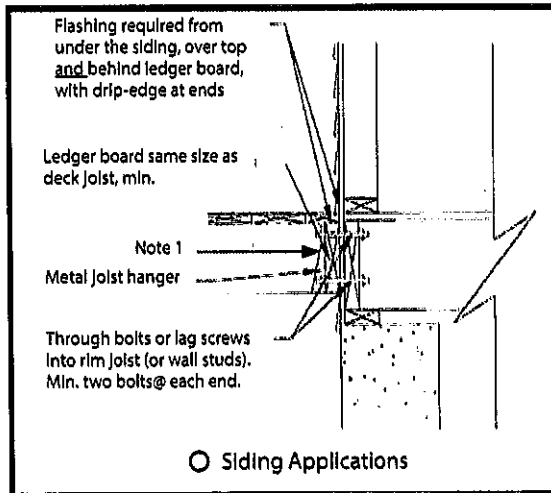

Ledger boards to be bolted with minimum 1/2" bolts 16" O. C. staggered top and bottom. Two bolts are required at each end. Note 1: Ledger boards that are parallel to the joists are not required to be bolted to the structure.